

## Mounting Instructions For Use With External Motor:

The Anzi Ceiling hood has the option to allow you to install an external motor away from the hood that can be ducted up to 6m away.

Luxair has 3 different external motors available:

- **Wall Mounted External Motor** - These motors are ideal for situating on an external house wall. They have a flat under carriage that fits flush against the wall.
- **Pitched Roof External Motor** - These motors are best in installed on an angled roof. They have an angled undercarriage so that the exhaust of the motor is not blowing directly on to your roof tiles.
- **Flat Roof External Motor** - These motors are best suited to being installed on a flat roof. A tower unit is provided to raise the motor from the roof so that the motor is not blowing directly on to your roof tiles.

**PLEASE NOTE THE EXTERNAL MOTORS MUST BE INSTALLED ON 6" ROUND OR RECTANGULAR EQUIVALENT DUCTING.**

### Installation:

- Locate where the motor will need to be secured and make sure there is a 6" ducting hole available.
- Attach the small metal duct supplied and secure the motor to the wall.
- Locate where the hood will be installed and make a cut out to size.
- Run ducting from the motor to where the hood is located
- Attach the 5m cable to the 1m cable on the motor and run this to the hood.
- Attach the ducting and cable to the hood and secure the hood in place.
- There is an access panel on the hood that allows access to the ducting and controls on the hood.

The ducting hole on both the hood and the motor are round. You will usually require an adapter/elbow as below to turn the duct 90 degrees. These are available in singles and are supplied in some of our ducting kits. Please be sure to check what ducting you will require before purchasing.

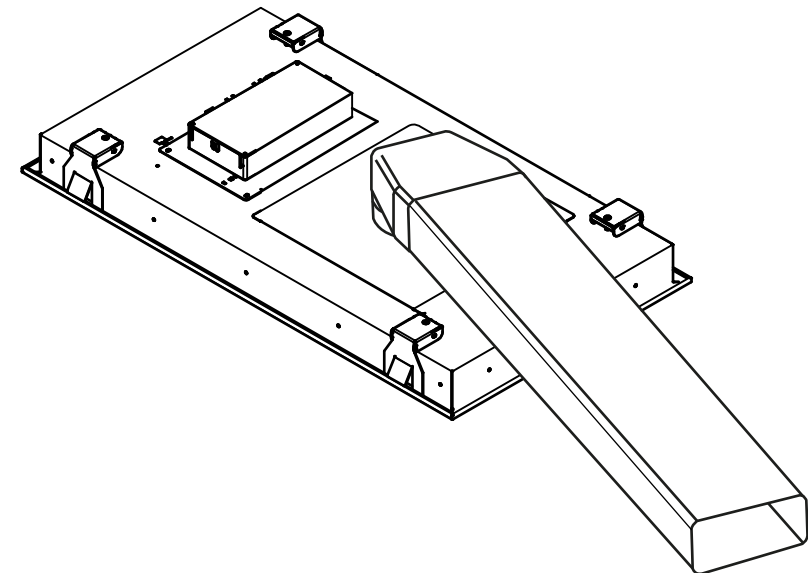
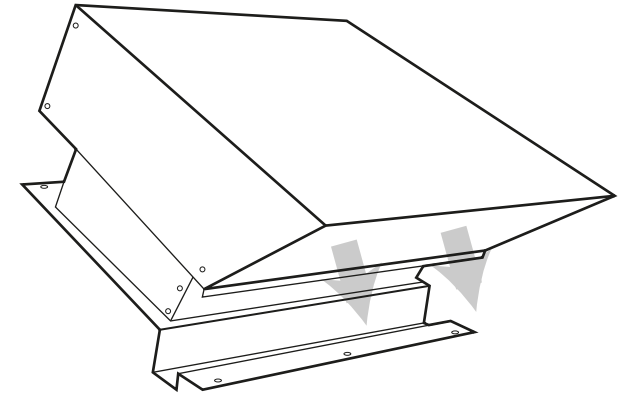



LUXAIR™  
EXTRACTION WITH ATTRACTION

6" - 180 x 95 Ducting Round to Rectangular Elbow

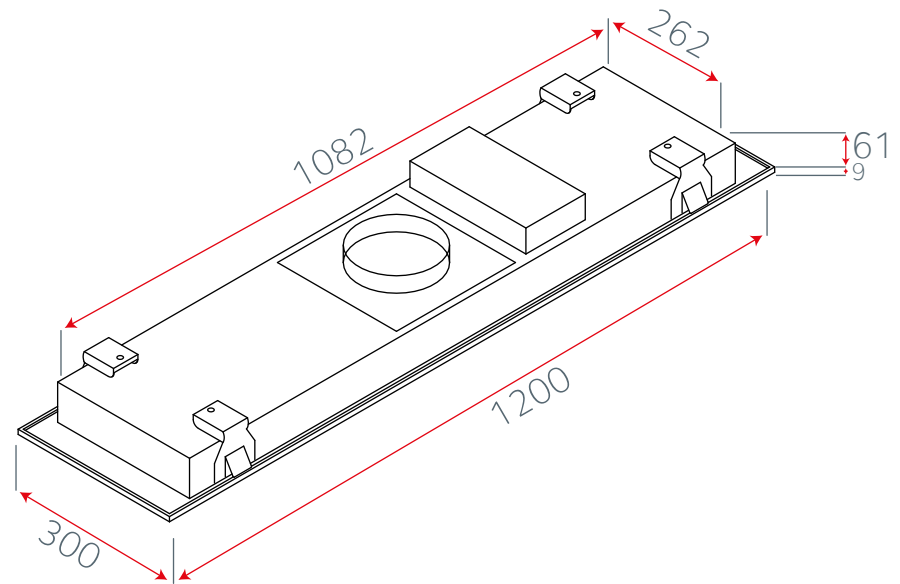
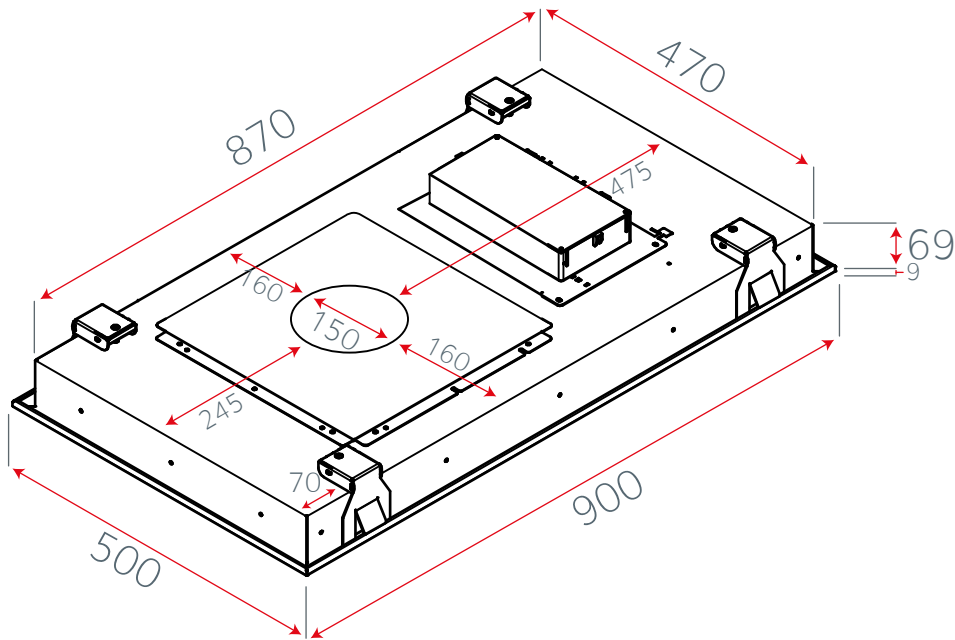
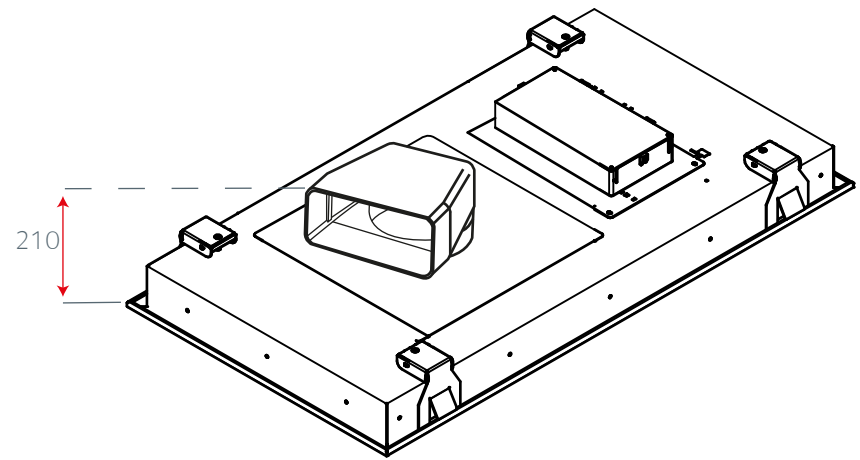
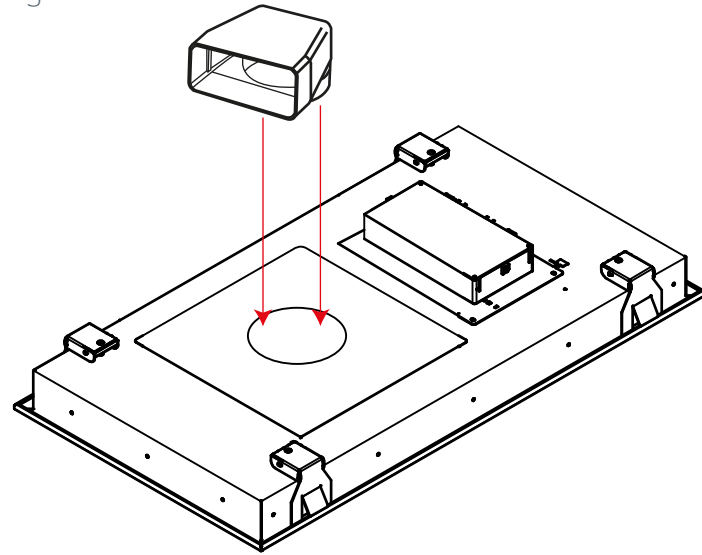
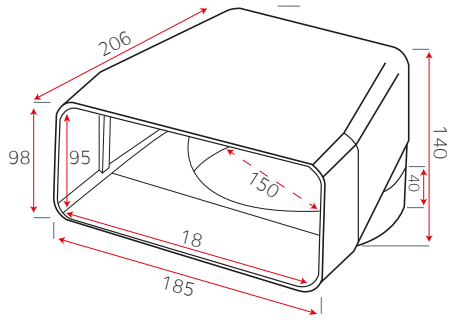

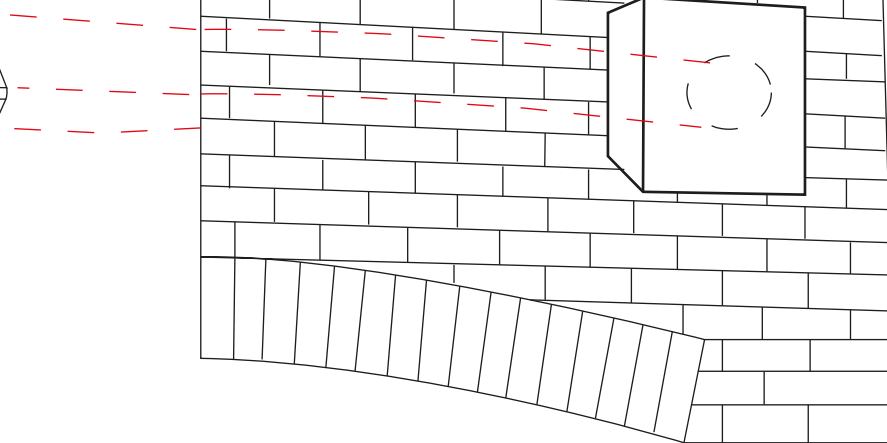
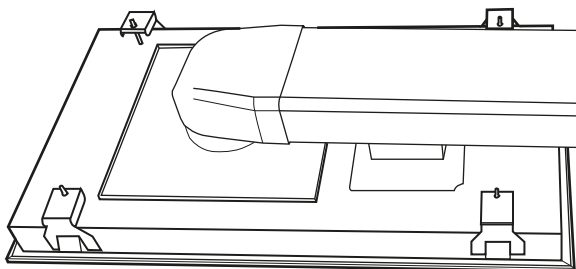

Wall Mounted External Motor

Pitched Roof External Motor

Flat Roof External Motor

